



All documents provided to you when your permit is issued must be on the job site when you call for an inspection.

A 24 hour automated inspection request system is available for the scheduling of inspections. These inspections may be scheduled via the telephone or online. All required inspections will be printed on your permit placard. In addition, you will receive a tri fold card that fits in your wallet to assist you with your inspections and a list of our inspector telephone numbers.



All inspections requested by 7:00 a.m. are done and resulted the same day by the **Building Department**.

Nothing is permitted within the easement; this includes the typical 5' easement located round the perimeter of the property.

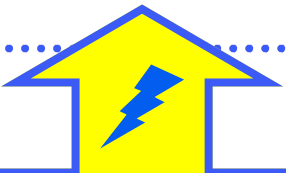

The electrician will be required to be on the site for the final inspection. Please call the chief building inspector the morning of your inspection at 8:00 a.m. to find out when the inspector will be at the job location.

Important Contact Numbers

The following numbers will be helpful during the process of obtaining your permit.

Building	386-986-3780
Inspection Line	386-986-4747
Zoning	386-986-3751
Stormwater	386-986-4760
Code	386-986-3764
Utility	386-986-2360
Property Appr	386-313-4150

Contact a Plans Examiner directly

Joe McGowen	386-986-3738
Susan Knopf	386-986-2463
Jean Joseph	386-986-4733
Fred Reodica	386-986-4734

Contact your Inspector directly

Art Cooper 386-931-6966 * Charlie 386-864-9059
 Darryl Rockwell 386-9316056 * Jerry Hindman 386-2066222
 Larry Hites 386-8649160 * Robert Marvel 386-864-9905

Office Hours

Monday thru Friday 8-4 p.m.

For documents/forms/additional information

WWW.CI.PALM-COAST.FL.US



What I need to permit a Generator

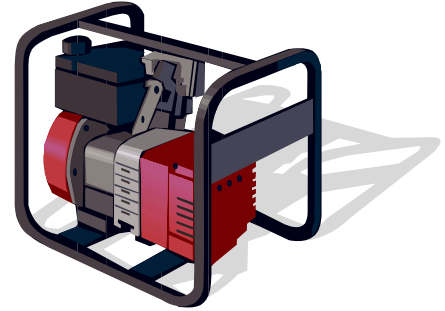

Building Division



City Walk Building
160 Cypress Point Pkwy.
Suite B-106
Palm Coast, FL 32164

Phone (386) 986-3780
Fax (386) 986-3781

NO EXCEPTIONS

We will issue this permit to a property owner, a gas, electrical, or mechanical contractor.

If the gas contractor obtains the permit, they must list the electrical contractor as a sub.

If the electrical company obtains the permit, they must list the gas contractor as a sub.

The mechanical contractor must list both gas and electrical subcontractors.

Landscaping/Screening is required if the Generator is in a visible area.

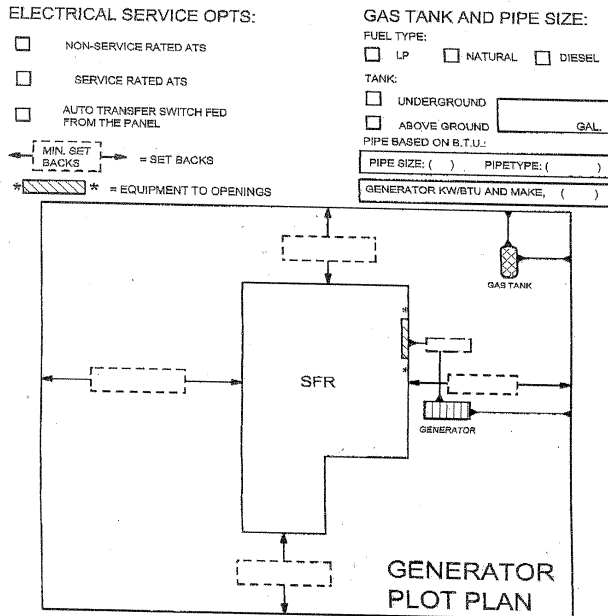

What I need to submit for a permit?

- ⇒ Permit application
- ⇒ recorded warranty deed
- ⇒ Site Plan depicting flood zone, size, location, setbacks, dimensions of generator and the concrete pad. Setbacks must include from house to generator, and generator to property line. Survey must show proposed gas tank, indicate if it is to be located above or below ground. Show dimensions, size, location and setbacks for the tank. Individual structures such as mechanical equipment and pumps shall be screened by property owner with visual buffer planting, when visible from rights-of-way, parking areas, or adjacent properties. In lieu of a visual buffer planting, solid decorative fencing or walls may be installed to screen from public view. Plants used shall be native or shall be vegetation that conserves water, is adaptable to local conditions, and is drought tolerant

- ⇒ Two (2) sets of plans to include: manufactures specifications including the generator transfer switch, the BTU rating of each appliance served, the type of pipe to be used, the size of pipe to each appliance and the length of the pipe run to each appliance.
- ⇒ Construction Lien Law affidavit
- ⇒ Notice of Commencement
- ⇒ Owner/Builder Disclosure (if applicable)

Facts about Generator/Gas tanks

- ⇒ Cannot be located in the Utility easement.
- ⇒ Underground tanks will Not be permitted in Special Hazard Flood Zones A & AE and must be 1 foot above base flood elevation if in a AE zone or 2 feet above the highest adjacent grade if in a Flood Zone A.
- ⇒ Individual structures such as mechanical equipment shall be screened by property owner with visual buffer planting, when visible from right-of-way, parking areas or adjacent properties. In lieu of a visual buffer planting, solid decorative fencing or walls may be installed to screen from public view. Plants used shall be native or shall be vegetation that conserves water, is adaptable to local conditions and is drought tolerant.
- ⇒ Finished Slab must be above base flood elevation if located in a special flood hazard area.

A permit is good for 6 months from the date of issuance.
If you do not obtain a passing inspection within 6 months, the permit WILL expire!!!

A new permit must be obtained if your permit expires. Full fees will be charged again.

Each failed inspection will be charged \$40.00

Notice of Commencement

You will be required to file a Notice of Commencement if the job value is greater than \$2500.00, greater than \$7500.00 for mechanical work.

You must file the Notice of Commencement at the Flagler County Court house at recording office